

MINUTES OF THE HOUSE ENERGY AND UTILITIES COMMITTEE

The meeting was called to order by Chairman Carl Holmes at 9:00 a.m. on March 2, 2010, in Room 785 of the Docking State Office Building.

All members were present except:

Representative Dan Johnson- excused  
Don Myers-excused  
Rob Olson-excused  
Mike Slattery-excused

Committee staff present:

Matt Sterling, Office of the Revisor of Statutes  
Cindy Lash, Kansas Legislative Research Department  
Iraida Orr, Kansas Legislative Research Department  
Artur Bagyants, Kansas Legislative Research Department  
Renaë Hansen, Committee Assistant

Conferees appearing before the Committee:

Don Low, KCC  
Christine Aarnes, KCC

Others attending:

Twenty Five including the attached list.

Informational briefings were presented by the Kansas Corporation Commission.

Don Low, KCC (Attachment 1) spoke to the committee on the basics of telecommunications. He began by giving a historical overview of the telecommunications industry beginning in the early 20<sup>th</sup> century. He then focused on the industry from 1996 to the present. He spent some time focusing on the current regulatory framework. Mr. Low then presented information on the advanced competition of delivering telecommunication services to subscribers because of the various kinds of services available to deliver the communication service. Those different technologies include: VoIP, Broadband, Land Line, and Wireless. He noted that at this time the KCC's involvement in interconnection issues and wholesale regulation is primarily limited to the review and approval of contracts that govern the relationship between two carriers and hearing complaints about whether carriers have violated provisions of the contracts. Included with his testimony was a power point presentation (Attachment 2) on telecommunications basics.

Questions were asked and comments made by Representatives: Annie Kuether, Tom Sloan, and Margaret Long.

Christine Aarnes, KCC (Attachment 3), gave a presentation to the committee on the current Kansas Universal Service Funds. She offered background information on how and why the funds initially were created. Ms. Aarnes indicated several programs that are supported with the KUSF funds. Additionally she spoke about the assessment rate that is implemented each year on March 1. She described the rules that certain carriers must meet in order to receive KUSF funds. She noted that the Universal Service in Kansas hands out support to carriers serving in high cost areas and support for low-income consumers. Included in her testimony were several attachments.

Questions were asked and comments made by Representatives: Tom Sloan, Vern Swanson, Annie Kuether, Tom Moxley, and Carl Holmes.

The next meeting is scheduled for March 3, 2010.

The meeting was adjourned at 10:20 a.m.

# HOUSE ENERGY AND UTILITIES COMMITTEE GUEST LIST

DATE: March 2, 2010

NAME	REPRESENTING
TOM DAY	KCC
Christine Aarnes	KCC
Mike Scott	AT&T
Tom Barkner	AT&T
Don Low	KCC
DAN JACOBSEN	AT&T
Nelson Knueger	SureWest
Kaylin McCrary	Guest
Michelle Peterson	Capital Strategies
<del>Nick Reese</del>	<del>Sprint</del>
John Ibrax	CenturyLink
Dina Fisk	Verizon
Jennifer Findley	KITA
John Helly	Wagner
Chad Jew	ATT

## Telecommunications Industry Overview

Presentation on behalf of the Kansas Corporation Commission  
Utilities Division  
Before the House Utilities Committee  
March 2, 2010

### Telecommunications Industry – Background

For most of the 20<sup>th</sup> century, the telecommunications industry was divided between the Bell System (companies owned by or affiliated with AT&T) and the Independents (companies not affiliated with AT&T). While the Independents covered more geographic area, the Bell System served the majority of lines throughout Kansas and the nation. (The rule of thumb was 80% of customers and 20% of geographic area.) Because it was believed that telecommunications service was a natural monopoly (one firm can serve customers more efficiently than many competing firms because of economies of scale), these companies were the sole supplier of the local telecommunications services in their certified territory. AT&T provided most of the long distance lines at that time. At this time, the telephone companies also owned the lines and equipment on a customer's premises. This industry structure led to high service quality and nearly universal service (high penetration/subscribership). Regulation was imposed to protect consumers from the potential for exploitation inherent with a monopoly. Regulation was enforced at both the state and federal level with the state responsible for monitoring local and intrastate long distance service and the federal regulator responsible for monitoring interstate long distance service. The precise lines of the jurisdictional divide under the federal Communications Act of 1934 have been drawn over time through FCC rulings and court decisions. However, one unusual feature of this federal law is the authority of the FCC to refer matters of mutual interest to a Federal-State Joint Board. With regard to the jurisdictional allocation of costs, Section 410(c) of the Act doesn't just authorize but requires FCC referral to a Joint Board.

Early regulation focused on apportioning costs to local and long distance services. Long distance calls were likely to travel along the lines and other facilities of several companies so a method of cost allocation was needed to reflect what was utilized in a long distance call. This was especially true after the Supreme Court decision in *Smith v. Illinois* that "local" facilities, such as the loop between the house or business and the central office, should be apportioned between local and long distance services since it carried both types of calls. The allocation of costs between the various services was referred to as the "separations" process, while the division of revenues generated from long distance calls among all the carriers in accordance with the cost allocations was known as the "settlements" process. The separations process was historically difficult because there was no one accepted method for allocating the cost of facilities used to provide both long distance and local services and the allocations formula

changed over time to reflect various considerations. One such consideration was a desire to encourage high subscribership – also known as “universal service” - by keeping local rates affordable. As technological improvements were made, the cost of long distance facilities decreased and profits increased. Rather than lowering long distance rates, the separations formula was revised to allocate more costs to long distance. All of this was accomplished within a rate-of-return regulation environment similar to that utilized for energy companies. A telecommunications carrier filed an application for rate changes when it believed it was no longer earning an acceptable return for its investors. However, because of the complexity of the Bell system and the correspondingly difficult accounting and cost allocation issues, there was some concern that both federal and state regulators weren’t fully up to the task.

By the 1970’s the industry began to change. New carriers like MCI went to court for the right to offer long distance service in competition with AT&T. Telephones and other “customer premises equipment” (CPE) no longer had to be rented from the customer’s local company. Computers were making inroads into services that had been provided by electromechanical switches owned by the local phone company. All of these changes complicated the separations and settlements process and led to many lawsuits and attempts at regulatory changes. A major change came in 1982 when AT&T and the Department of Justice entered into a consent decree to end a long antitrust suit. Under that decree, AT&T agreed that it would divest itself of all of the regional Bell Telephone companies (what would become known as a Bell Operating Company (BOC)) but would keep research divisions and all assets related to “long distance” service. AT&T would be free to enter into any type of business but could not buy stock or assets of a BOC. A BOC could provide only local and intraLATA service. (LATA stands for Local Access and Transport Area. These areas were established as part of the implementation of the consent decree with input from all interested parties. In Kansas, the LATA’s corresponded with the area code boundaries except for an area around Kansas City.)

The Federal Communications Commission (FCC) recognized that these major industry changes required a new cost recovery scheme. In 1983, the FCC proposed that consumers pay a flat rate charge associated with the interstate portion of the local loop while long distance companies reimbursed local companies for the other costs of providing the origination or termination of a call. However, there was much concern that a flat charge for consumers would lead to lower subscribership and states challenged the FCC’s authority to impose charges on local service. Eventually a much lower flat rate charge, to be known as the subscriber line charge, was agreed to and went into effect in 1984. That SLC has gradually increased over the years.

### **Telecommunications Industry – 1996 to Present**

By the mid-1990s more technological changes had occurred and it was believed that competition could be introduced into the local market bringing consumer benefits as it had for the long distance consumer. On February 8, 1996, the Federal Telecommunications Act (FTA) was signed into law. It ushered in a new era for the telecommunications industry and new role for government regulation of that industry. That same year, the Kansas Legislature enacted the Kansas Telecommunications Act (KTA) to promote competition in local markets. While many carriers desired to enter into the local market, the RBOCs were eager to enter into the interLATA

long distance market. Section 271 of the FTA set forth the conditions for obtaining such authority. SBC received interLATA authority in Kansas in 2001 and all RBOCs have that authority now so that the distinction between interLATA and intraLATA service has less ramifications now than before.

Both the FTA and KTA required Commission action to achieve the goals of the policy changes. In implementing provisions of the FTA and KTA, the Commission has been guided by the public policy declaration in K.S.A 66-2001. In brief, this statute declares it to be the policy of the state to ensure all Kansans have access to quality telecommunications services at an affordable price; ensure all Kansans realize the benefits of competition through improved service at reduced rates; promote access to a full range of telecommunications services, including advanced services at comparable rates in urban and rural areas; and protection of consumers from fraudulent business practices and practices inconsistent with the public interest. In developing a competitive market for local telecommunications services, both the KTA and the FTA emphasized maintaining universal service. In implementing provisions of the KTA and FTA, the Commission has also been guided by this principle.

#### Current Regulatory Framework

The basic framework for KCC regulation of telecommunications providers and services is mostly contained K.S.A. 66-2005. It has been amended several times since the original passage of the KTA.

Incumbent local exchange carriers, of which there are 39, may continue to be subject to rate of return regulation or elect to be subject to price cap regulation. Two companies, AT&T and CenturyLink have elected price cap regulation. There are also recent provisions regarding total price deregulation with regard to bundled services and for individual exchanges.

“Telecommunications carriers” is the category of providers that includes the competitive providers – long distance providers, (IXCs or interexchange carriers) and CLECs (competitive local exchange carriers). The KCC has no authority over their rates, but they are required to obtain certificates and file tariffs. In addition they are subject to the same quality of service and billing standards as the ILECs, and also to KCC oversight to “prevent fraud and other practices harmful to consumers.”

Wireless – due to both Kansas statutes and the FTA, KCC has no jurisdiction over wireless providers, (radio common carrier or commercial mobile radio service provider. However, a wireless provider that is also an ETC is subject to the KCC requirements otherwise applied to ETC’s.

VoIP – although the FCC has suggested that Voice over Internet Protocol is an interstate service it has yet to make a definitive ruling on how such services should be regulated or, for that matter, what constitutes VoIP service. When VoIP is used, a voice communication traverses at least a portion of its communications path in an IP packet format using IP technology and IP networks. VoIP can be provided over the public internet or over private IP networks. Unlike traditional circuit-switched telephony, which establishes a dedicated circuit between the parties to a voice transmission, VoIP relies on packet-switching, which divides the voice transmission into packets and sends them over the fastest available route. Thus, VoIP uses available bandwidth more efficiently than circuit-switched telephony and allows providers to maintain a single network for both voice and data. Since traditional ILEC’s are consequently replacing their old networks with

packet-switched technology, there is room for a lot of confusion on whether a service should be exempt from state regulation.

Advancement of Competition

The FTA and KTA required the FCC and KCC to implement policies to advance competition. Over the years, interpretations of the FTA have varied and policies decisions of the FCC have been altered and required states to modify their implementation schemes. Decisions by the Courts have also modified the policy direction given to states. As policy has developed over the years, the types and number of competitors has shifted. At this time, the cable based providers are the most prevalent land-line competitor. At the national level, cable based providers serve 31% of the total number of lines served by competitive carriers and 71% lines served by facilities-based competitive carriers.<sup>1</sup> At the same time, wireless service has become more prevalent and long distance service is on the decline. Broadband technology is allowing a new mode of provisioning telecommunications using internet protocol. This method of provisioning is referred to as Voice over Internet Protocol (VoIP).

a) Land-line Carriers

As of October 30, 2009, the Commission has authorized 129 competitive local exchange carriers (CLECs) to provide local telephone service in the exchanges of ATT and CenturyLink. The number of CLECs has been larger in prior years; however, as conditions for entry into the local market have changed, many CLECs have exited the market. For those that remain, Annual Reports filed with the Commission indicate that approximately 64 CLECs were actually serving customers in Kansas. Of those CLECs, 12 were facilities-based providers providing service entirely over their own facilities, 25 resold the services of the incumbent local exchange carrier (ILEC), 11 were providers utilizing a commercial agreement, and another 16 provided service via a combination of resale, facilities-based modes of provisioning, and commercial agreements. Of the ten CLECs serving the most lines in Kansas, seven are facilities-based providers.

While the number of land-line competitors has declined, the CLECs that remain have gained market share over the years. The most recent data from the Federal Communications Commission (FCC) indicate that by June 30, 2008, CLECs served 28% of the local market in Kansas compared with 19% nationwide.<sup>2</sup> As illustrated by the chart below, the FCC's data indicate that the CLECs' share of the market in Kansas has increased, nearly consistently, since 2001.

CLEC Share of End User Access Lines<sup>3</sup>

	June 2001	June 2002	June 2003	June 2004	June 2005	June 2006	June 2007	June 2008
Kansas	8 %	12 %	21 %	22 %	25 %	24 %	25 %	28 %
Nationwide	9 %	11 %	15 %	18 %	19 %	17 %	18 %	19 %

<sup>1</sup> Local Telephone Competition: Status as of June 30, 2008, Industry Analysis and Technology Division, Wireline Competition Bureau, Federal Communications Commission, Released July 2009, Table 5.

<sup>2</sup> Id., Table 7.

<sup>3</sup> Id., Table 8.

The number of interexchange service providers authorized by the KCC to offer intrastate (long distance or toll) service in Kansas was 290, as of October 30, 2009. While once there were over 400 carriers certified to offer service in Kansas, changes in technology have led consumers to turn to alternative means of long distance communication.

b) Wireless Carriers

One of those alternative means of long distance communication is wireless communications. According to the FCC, there are over 2 million subscribers to wireless service in Kansas. FCC data reveal that wireless subscribers have increased by 9% from June 2007 and by 158% since June 2001.<sup>4</sup>

Kansas Wireless Subscribers<sup>5</sup>  
(11 Carriers Reporting)

June 2001	June 2002	June 2003	June 2004	June 2005	June 2006	June 2007	June 2008
901,225	1,061,171	1,195,230	1,345,160	1,659,662	1,905,342	2,133,399	2,326,444

The Commission's authority over wireless carriers is limited to collection of assessments for the Kansas Universal Service Fund (discussed briefly below) and requirements for those that have been designated as carriers eligible to receive federal or state universal service fund support. Therefore, the Commission has limited data on wireless carriers. According to universal service fund contribution data, there are 43 wireless carriers (including those that provide only paging services), providing service in Kansas.

It should be noted that wireless service is increasingly becoming a substitute for land line voice service. A recent study by the Centers for Disease Control (CDC) indicates that approximately 21% of households use only wireless service.<sup>6</sup> Other data on wireless usage from the CDC indicate:

Two in five adults renting their home (40.9%) had only wireless telephones. Adults renting their home were more likely than adults owning their home (12.8%) to be living in households with only wireless telephones.

Nearly half of adults aged 25-29 years (45.8%) lived in households with only wireless telephones. More than one-third of adults aged 18-24 (37.6%) and approximately one-third of adults aged 30-34 (33.5%) lived in households with only wireless telephones.

<sup>4</sup> Id., Table 14.

<sup>5</sup> Id., Table 14.

<sup>6</sup>Blumberg SJ, Luke JV. Wireless substitution: Early release of estimates from the National Health Interview Survey, January-June 2009. National Center for Health Statistics. December 2009. Available from: <http://www.cdc.gov/nchs/data/nhis/earlyrelease/wireless200912.pdf>

As age increased from 35 years, the percentage of adults living in households with only wireless telephones decreased: 21.5% for adults aged 35-44; 12.8% for adults aged 45-64; and 5.4% for adults aged 65 and over. However . . . the percentage of wireless-only adults within each age group has increased over time.<sup>7</sup>

c) VoIP

Because the Commission's jurisdiction over VoIP providers is uncertain and limited the Commission has little data on the number of VoIP providers in Kansas. To implement the statutory requirement to collect universal service fund assessments from VoIP providers, the Commission has relied on information self-reported by carriers or collected by the FCC to identify providers serving Kansas customers. Nineteen carriers self-reported the offering of VoIP services in Kansas while the FCC data indicate there are an additional 61 carriers that may offer service in Kansas.

Broadband

There has been much desire by both the Legislature and national leaders to expand the reach of broadband services to more rural areas. In Kansas, customers in rural areas served by independent ILECs have seen broadband deployed more rapidly than customers in rural areas served by ATT or CenturyLink. The more rapid deployment by independent ILECs has primarily been fueled by the greater amount of USF support received by these carriers. While the Commission has no jurisdiction over the provisioning of broadband service, over the years the Commission has taken advantage of opportunities to encourage ATT and CenturyLink to deploy broadband and has negotiated more rapid deployment of broadband services to areas of the state than otherwise may have occurred.

With the passage of the American Recovery and Reinvestment Act, grants are available for the deployment and mapping of broadband services, as well as for programs that will encourage adoption of broadband services. The Kansas Department of Commerce has taken the lead in the broadband mapping effort and in developing criteria for evaluating broadband deployment proposals and I understand it provided information last week on Connect Kansas.

Below is data collected by the FCC on broadband availability:

---

<sup>7</sup> *Id.*



called upon to arbitrate when carriers are not able to reach an agreement on one or more of the provisions that are typically included in an Interconnection Agreement.

One aspect of these contracts that receives much attention is compensation for handling various types of traffic. Over the years, different compensation schemes have been developed for different types of traffic. As discussed before, long distance providers pay access charges to local carriers for the origination and termination of long calls. Local companies that are interconnected and exchange local traffic pay "reciprocal compensation" for termination of calls. However, the function provided for each is quite similar. As these services compete with each other, carriers have been pressing the FCC to address intercarrier compensation in a unified manner. It is expected that the FCC will attempt to address the proper level of compensation owed carriers for the origination and termination of various types of traffic. The difficulty is that moving toward a unified approach will likely reduce the amount of revenues that local carriers recover from "intercarrier compensation." To make up for those revenues, the alternatives are to increase basic rates, the SLC's, or draws from the Universal Service Fund.

Number of High-Speed Service Providers, by Technology, as of June 30, 2008<sup>8</sup>

<u>State</u>	<u>ADSL</u>	<u>Cable</u>	<u>Other *</u>	<u>Total No. Unduplicated Providers</u>	<u>Change from 6-07</u>
Kansas	38	26	81	86	+ 5
Missouri	44	18	84	92	+ 4
Oklahoma	39	10	76	77	+ 5
Colorado	30	13	59	73	+ 9
Nebraska	34	16	57	68	+ 3

The data indicate that Kansas has attracted 86 broadband service providers (a gain of 5 from December 2007) and compares favorably with adjacent states.

High-Speed Lines (in service) by Technology, as of June 30, 2008<sup>9</sup>

	<u>ADSL</u>	<u>Cable</u>	<u>Other *</u>	<u>Total</u>
Kansas:				
- 6/07	216,800	351,371	309,940	869,111
- 6/08	240,921	380,063	442,936	1,063,920
% of Total	22.6%	35.7%	41.6%	
National:				
- 6/07	27.5M	34.4M	38.3M	100.2M
- 6/08	30.0M	38.1M	64.7M	132.8M
% of Total	23%	29%	49%	

\* Other includes wire-line technologies other than ADSL, fiber optics to the subscriber's premises, satellite, terrestrial wireless systems, power lines, etc.

The data indicate that the technology mix in Kansas is consistent with national deployment trends. Between June 2007 and June 2008, the number of ADSL lines in Kansas increased by 11%, broadband over cable subscribers increased by 8%, and the number of broadband lines served by other technologies increased by 43%. The overall annual growth rate for Kansas was 22%. This was less than the overall growth rate for the nation as a whole which was 32%. There was substantially more growth in the "other" category on a nationwide basis than in Kansas.

Interconnection/Wholesale Regulation

At this time, the Commission's involvement in interconnection issues and wholesale regulation is primarily limited to the review and approval of contracts (known as Interconnection Agreements) that govern the relationship between two carriers and hearing complaints about whether carriers have violated provisions of the contracts. From time to time, the Commission is

<sup>8</sup> High-Speed Services for Internet Access: Status as of June 30, 2008, Industry Analysis and Technology Division, Wireline Competition Bureau, Federal Communications Commission, Released July 2009, Table 8.

<sup>9</sup> Id., Table 9.

# Telecommunications Basics

---

Presentation  
for  
House Utilities Committee  
March 2, 2010

Utilities Division  
Kansas Corporation Commission  
1500 SW Arrowhead Road, Topeka, KS 66604

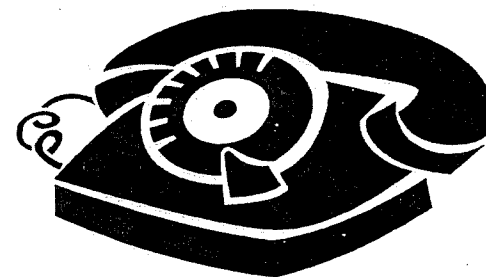

# Telecommunications Basics

---

## The Early Years





# Telecommunications Basics

---

- Brief History
- Types of Service
- Local Call
- Long-distance Call
- VoIP Call
- Jurisdiction
- Rate Structure



# Telecommunications Basics

---

- Types of Service
  - Local Service
    - Basic Voice Service
    - Discretionary Services
  - Long distance Service
  - Broadband Service
    - Internet Access
    - Voice Over Internet Protocol
  - Wireless Service
  - Bundles of Services

# Telecommunications Basics

---

## The Telephone Number

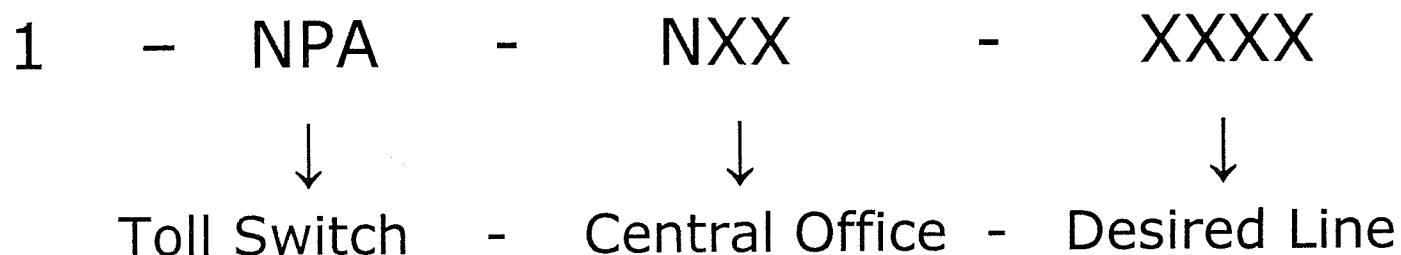

"1" indicates a toll call.

"N" = 2-9

"X" = 0-9

Total numbers per NPA=7.92 million

# Telecommunications Basics

## The Public Switched Telephone Network (PSTN) Prior to 1984

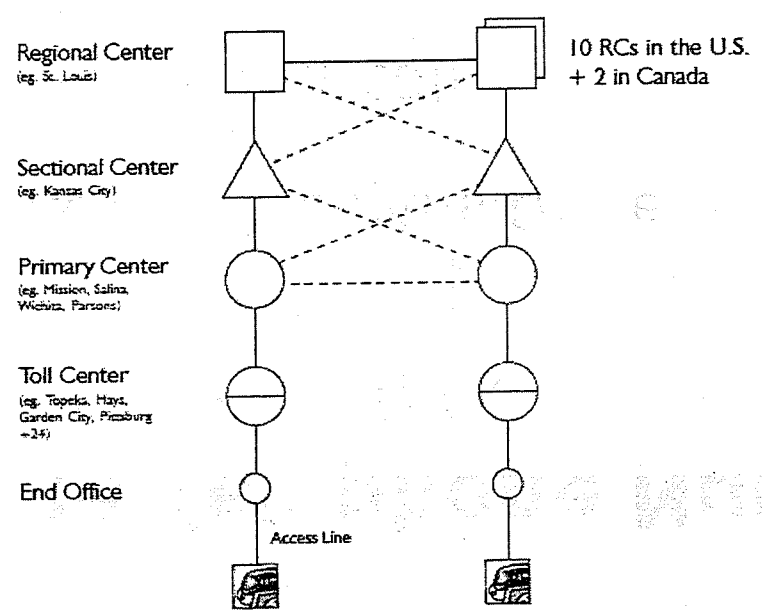

Legend:

— = Large (several hundred) 'Final' trunk groups of inter-office trunks.

- - - = Smaller 'high usage' trunk groups sized to carry ~ 80% of the offered traffic.



# Telecommunications Basics

---

**Local Call**  
**Same Central Office**

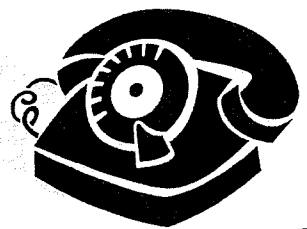

271-1234

Local Loop

**End Office or  
Central Office**  
271

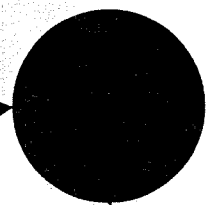

Local Loop

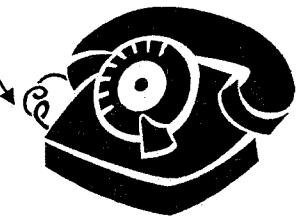

271-4321

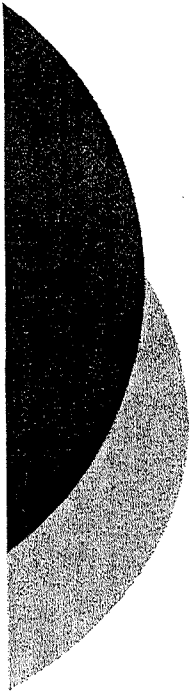

# Telecommunications Basics

---

## Local Call Multiple Central Office

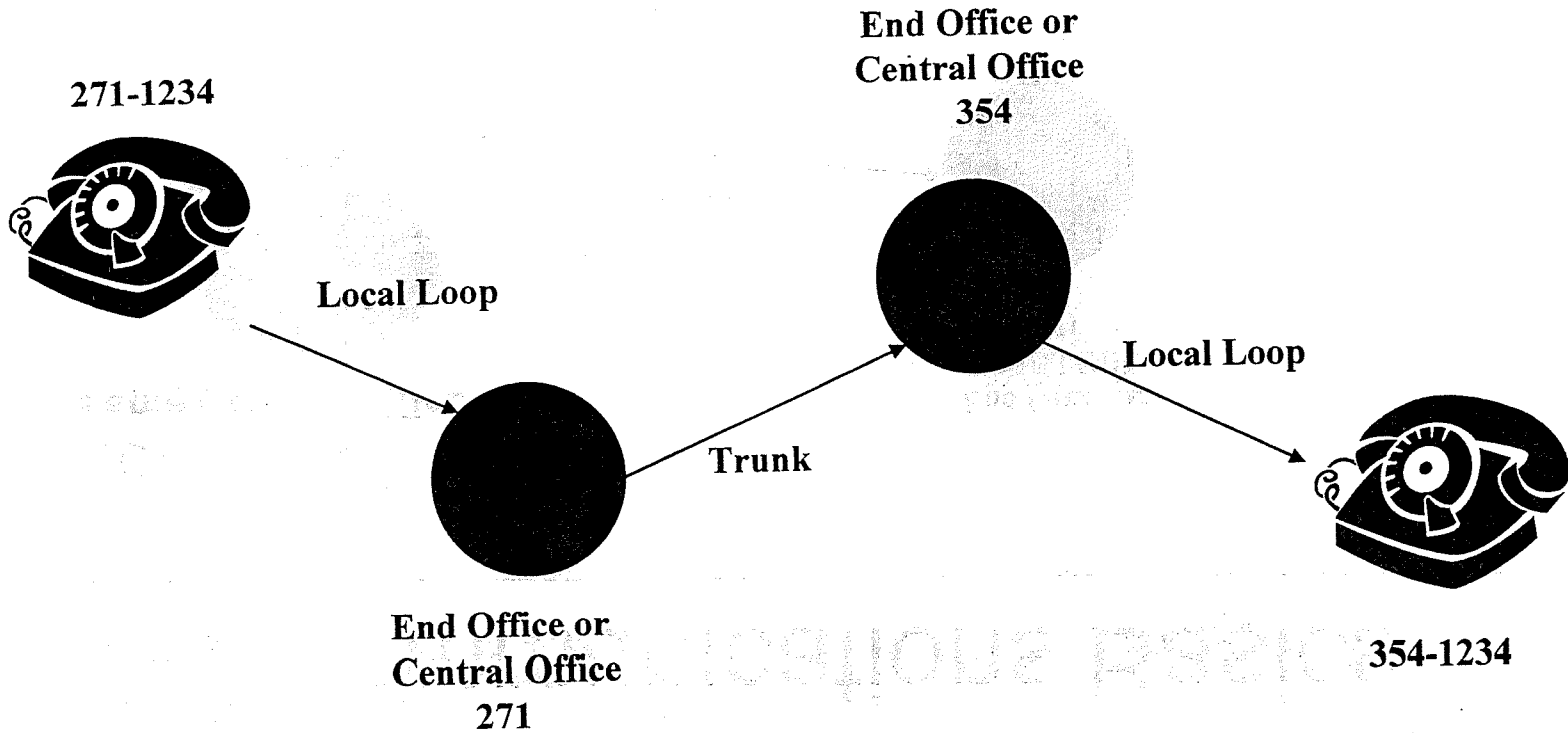

# Telecommunications Basics

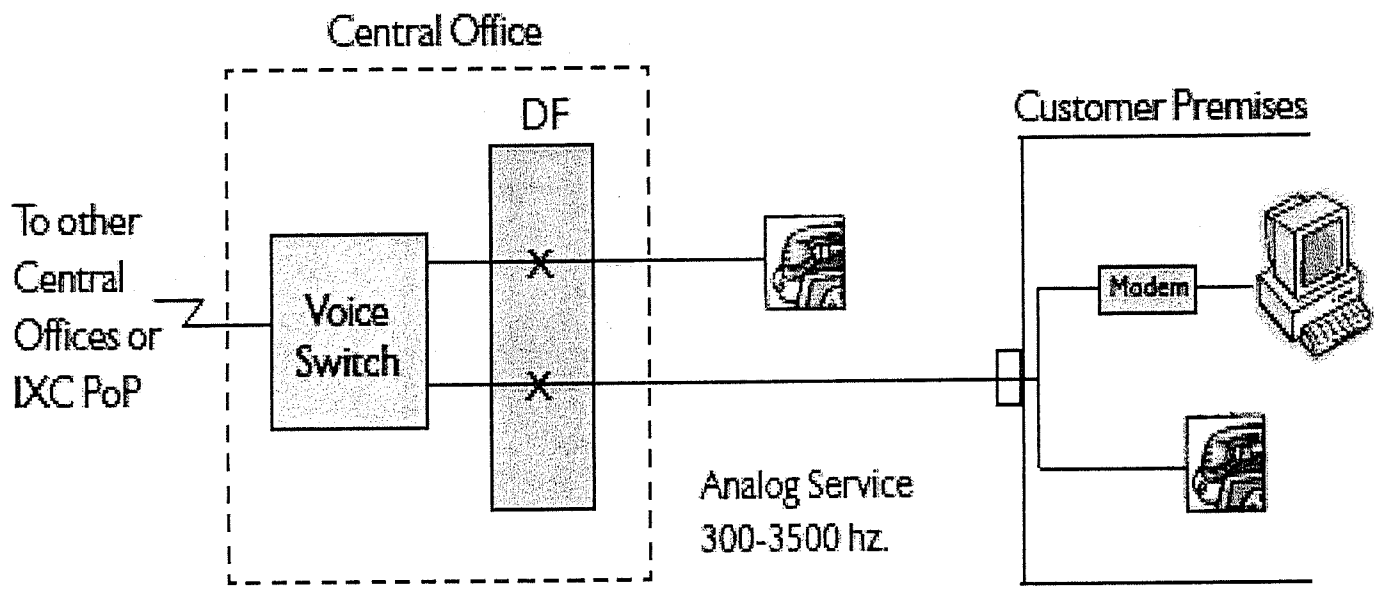

# Telecommunications Basics

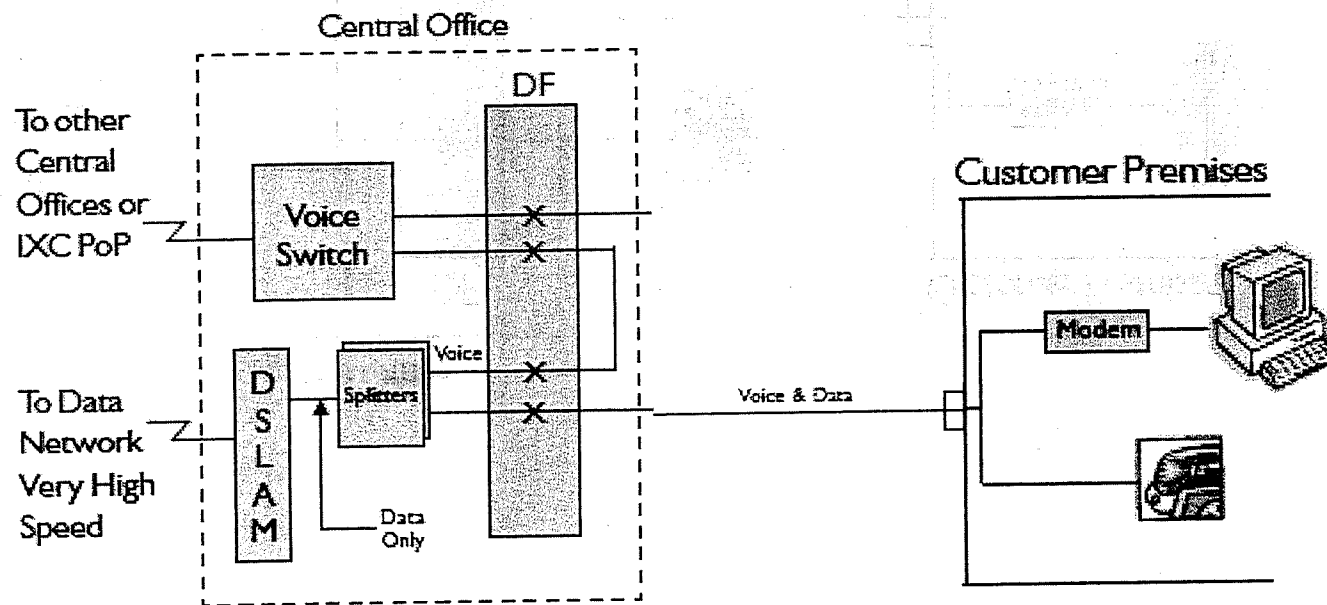

# Telecommunications Basics

---

## Long Distance Call IntraLATA Long Distance Call

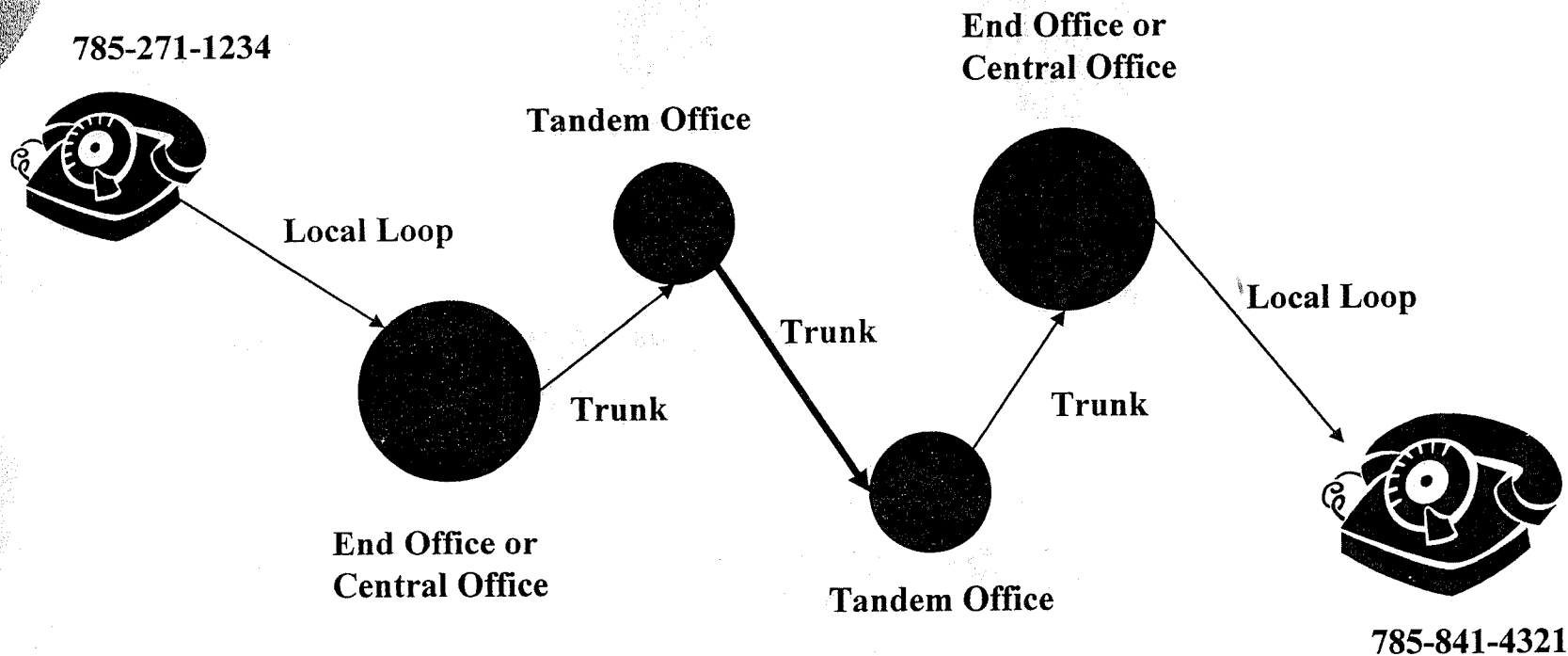

# Telecommunications Basics

## Long Distance Call InterLATA Long Distance Call

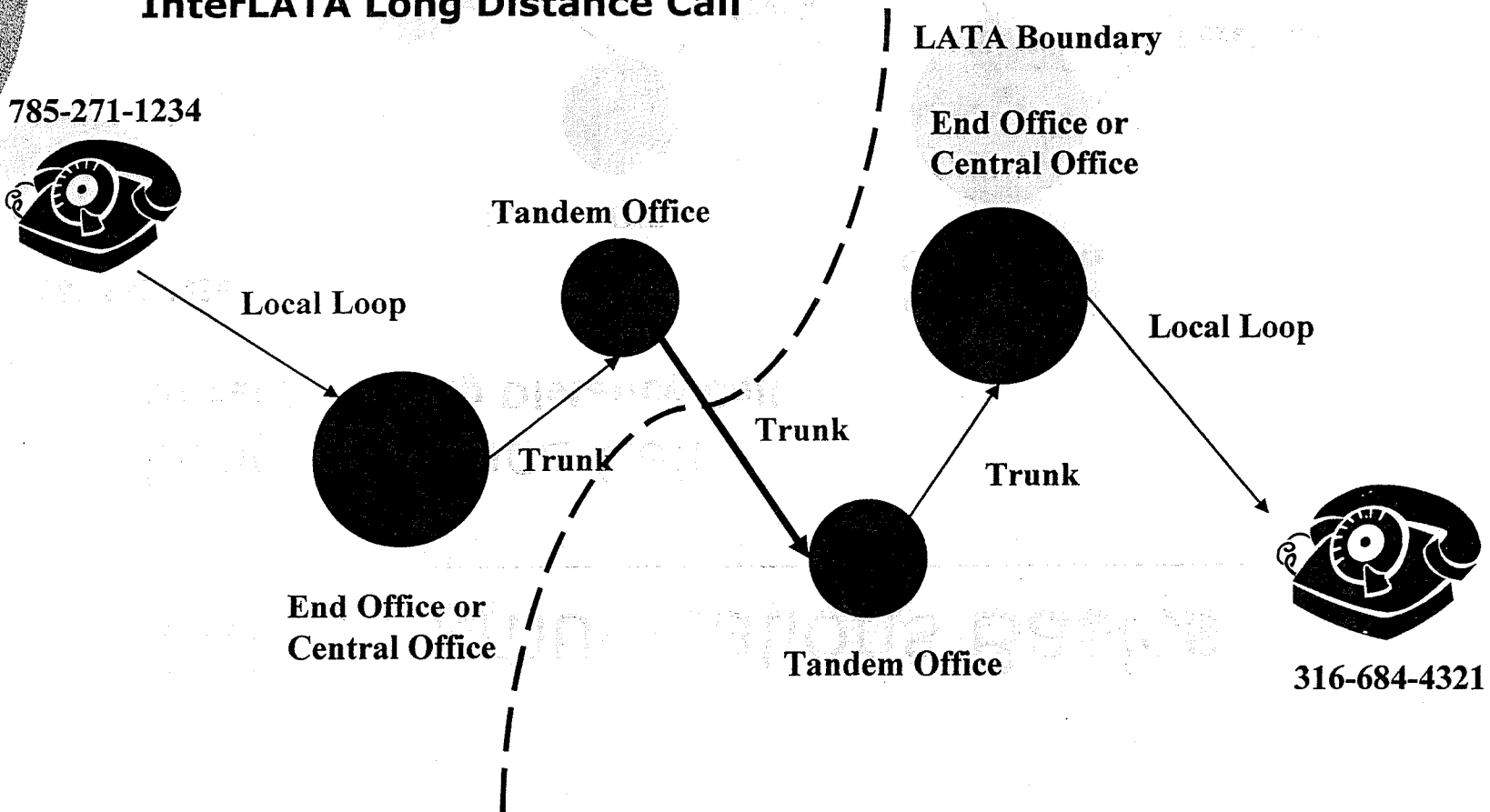

# Telecommunications Basics

---

## VoIP Call

**Voice Over Internet Protocol to Landline**

**Voice Over Internet Protocol to Voice Over Internet Protocol**

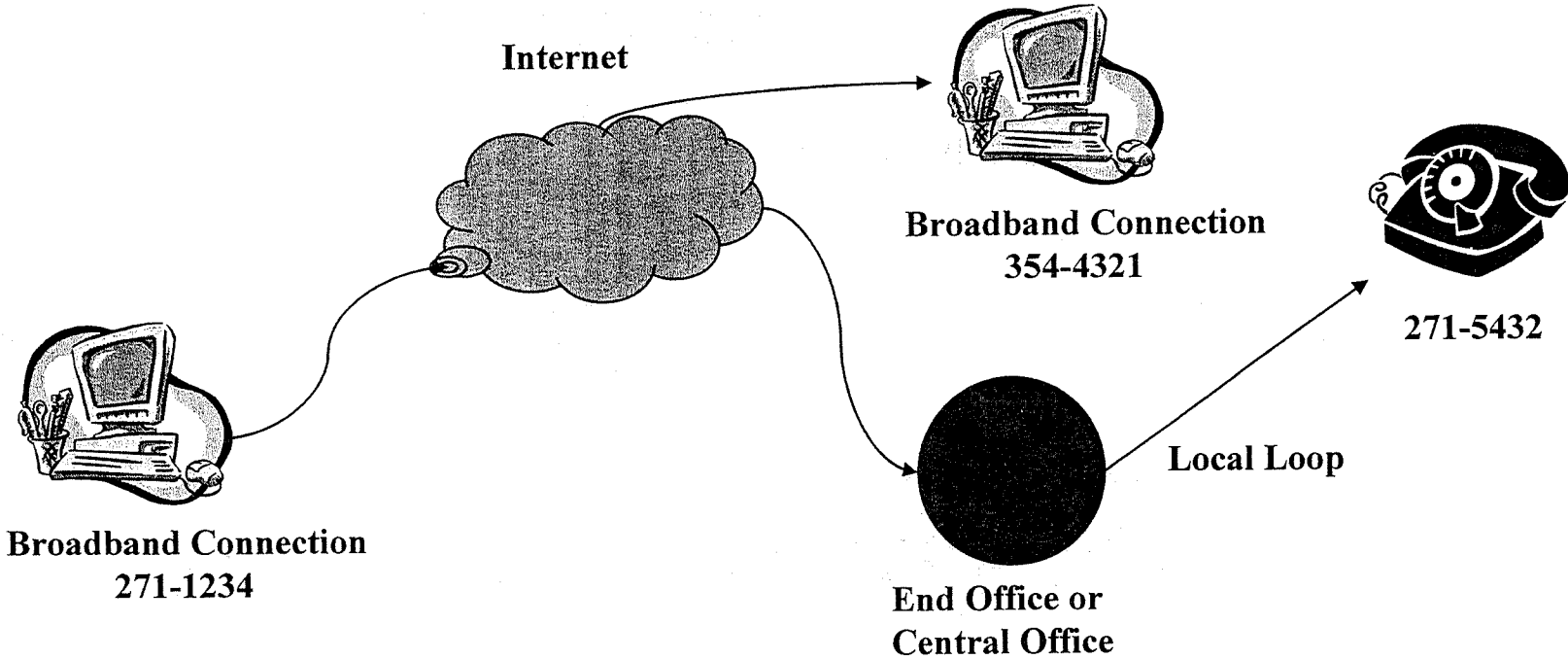

# Telecommunications Basics

---

## Wireless Call

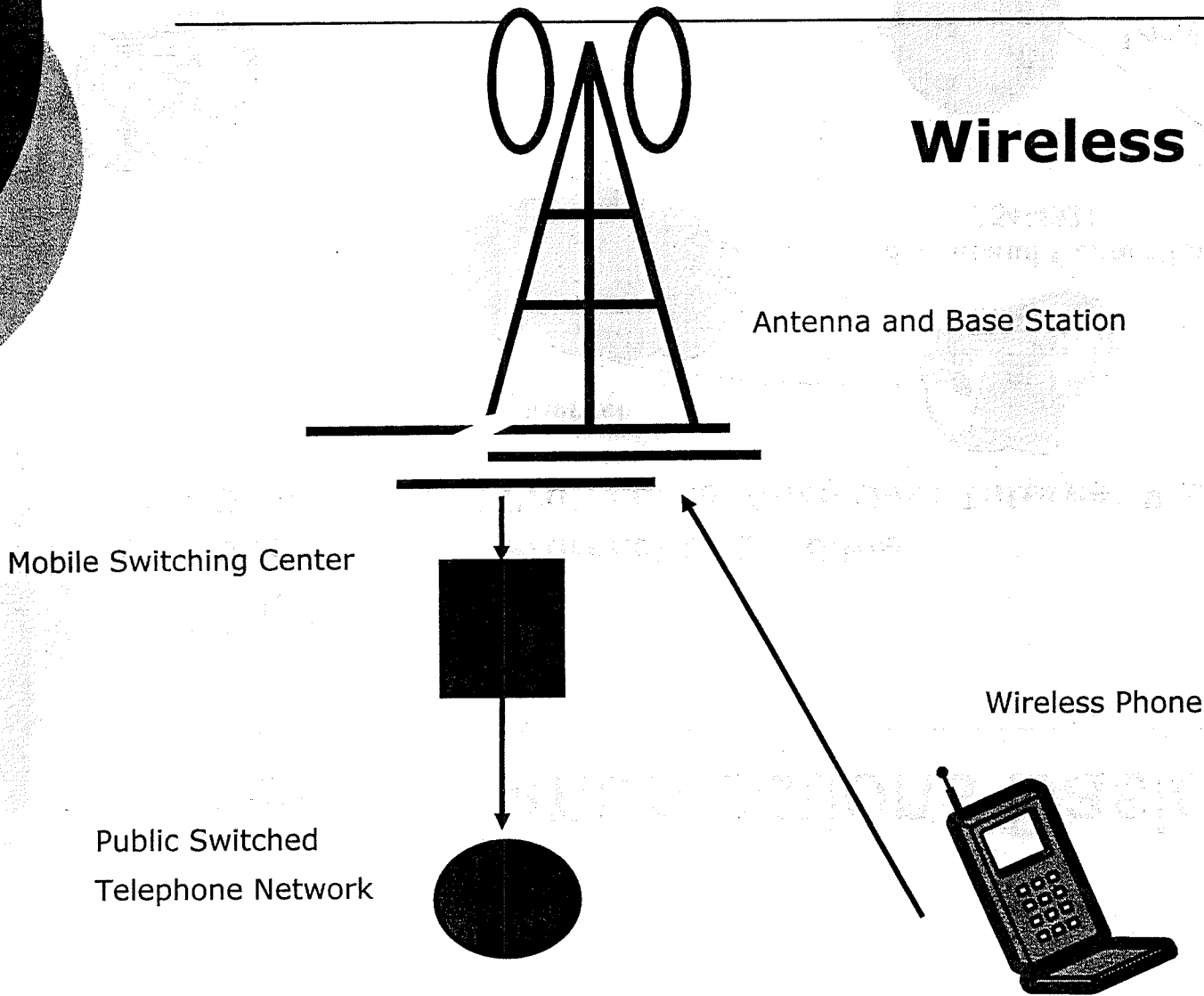



# Telecommunications Basics

---

## Jurisdictional Authority

The KCC has jurisdiction over **intrastate** calls and carriers.

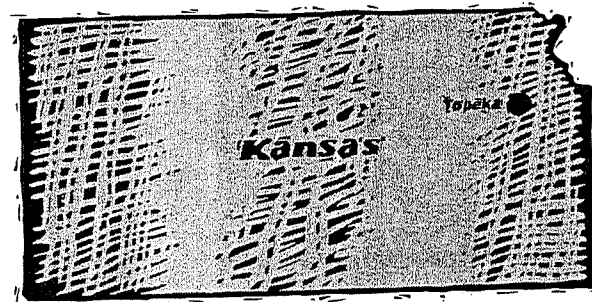

The FCC has jurisdiction over **interstate** calls and carriers.

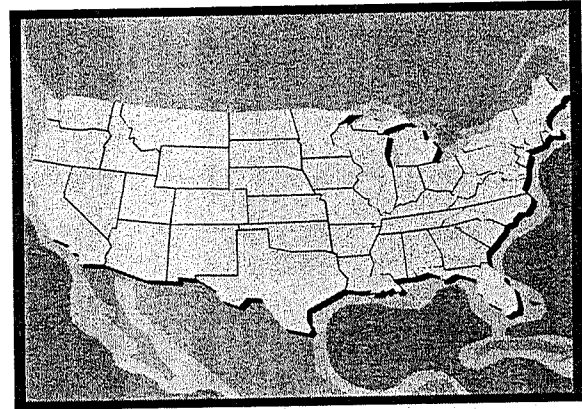

# Telecommunications

---

- Types of Regulation

- Rate Regulation

- Rate-of-return

- Price-cap

- Service Quality

- Billing

- Interconnection



# Telecommunications Basics

---

- KCC Jurisdiction
  - Incumbent Local Exchange Carriers (ILEC)
  - Competitive Local Exchange Carriers (CLEC)
  - Long-distance Carriers (IXC)
  - Wireless Carriers
  - VoIP Carriers

# Telecommunications Basics

---

- **Rate-of-Return Regulation**

- There are two steps to implementing rate of return regulation:
  - First, determine the economically appropriate revenue requirement. This is based on prudently incurred expenses and a "fair" return on invested capital, and
  - Second, set prices for individual services so revenue earned from all the regulated services is not greater than the revenue requirement.
- The revenue requirement is generally calculated using the following formula:

$$\text{Revenue Requirement} = \text{Operating Expenses} + \text{Depreciation} + \text{Taxes} + (\text{Net Book Value} * \text{Rate of Return})$$



# Telecommunications Basics

---

## ○ Price-cap Regulation

- Prices are adjusted using an index rather than through an examination of cost of service.
  - In most instances, price-cap regulation begins after a traditional rate of return review of the cost of providing service.
  - In some applications, there are periodic rate of return reviews to rebase the rates to match the cost of providing service if necessary.
- The Price Cap formula utilized by the KCC is:  
Price Cap Index = Inflation – Productivity Offset +  
Extraordinary Event Adjustment

# Telecommunications Basics

---

- Interconnection

- Review Carrier to Carrier Agreements
- Arbitrate or Mediate Agreements
- Complaints



Mark Parkinson, Governor  
Thomas E. Wright, Chairman  
Joseph F. Harkins, Commissioner

Briefing on the Kansas Universal Service Fund  
Before the House Energy and Utilities Committee  
March 2, 2010  
Christine Aarnes, Senior Managing Telecom Analyst  
On behalf of the Kansas Corporation Commission

Chairman Holmes and members of the House Energy and Utilities Committee:

Thank you for the opportunity to discuss the Kansas Universal Service Fund with you. As you are aware, both the Kansas Telecommunications Act of 1996 (Kansas Telecom Act) and Federal Telecommunications Act of 1996 (Federal Telecom Act) contain provisions to develop universal service funds to maintain and enhance universal service. The Federal Telecom Act allows states to develop their own universal service funds as long as the funding policies are consistent with those of the federal fund.

The funds are known as the Kansas Universal Service Fund (KUSF) and the federal Universal Service Fund (USF). The KUSF began operations on March 1, 1997 and on March 1, 2010 started its fourteenth year of providing support to local telephone service providers to assist in making universal service available in high cost areas of the state, to provide dual-party relay service and telecommunications equipment for persons with disabilities and to provide assistance to those with lower incomes through the Lifeline program. For the last several years, the KUSF has also provided funding for Kan-Ed. Currently, the fund is meeting requirements totaling approximately \$70 million.

#### Background

Kansas statute, K.S.A. 66-2008(a)<sup>1</sup>, dictated that KUSF support would initially be available to incumbent local exchange carriers in an amount equal to revenue that would be lost when access charge reductions were implemented as required by K.S.A. 66-2005(c). Access charges are the prices long distance carriers pay local carriers for the origination and termination of long distance calls. It is essentially the rate paid by the long distance carrier to use the local carrier's network to transport the call. These charges were historically higher than the actual cost of providing the service and the revenue from these charges contributed to keeping rates for local service lower than they otherwise would have been. When local carriers were not allowed to provide interLATA long distance services, there was less pressure to move rates to a level that reflected the cost of providing access service. However, with the passage of the Federal Telecom Act, local service providers would have an opportunity to enter the long distance market and long distance providers feared these carriers would have a cost advantage if access charges were not modified. The Federal Communications Commission (FCC) and the Kansas Legislature believed that access charges should be reduced but neither believed it should be done if universal service would be compromised by increases to basic local rates. Therefore, as access

<sup>1</sup> K.S.A 66-2008 has been amended and subsection (a) no longer reflects this requirement.

charges were reduced, local carriers were allowed to recover at least some portion of lost access revenue from the USF and the KUSF. In Kansas, price-cap carriers such as AT&T and CenturyLink have moved intrastate access charges toward parity with interstate access charges on two occasions. Independent local carriers are required by statute to mirror interstate access charges every two years.

While the initial amount of KUSF support was set to replace lost access charge revenues, K.S.A. 66-2008(c) requires that the Commission periodically review the KUSF to determine if the cost to provide service of local carriers eligible to receive such funds justifies modification of support. The Commission has answered this requirement by mirroring efforts by the FCC to meet a similar charge. For carriers like AT&T, the FCC determined that support should be based on the cost to provide service if the network were being built given current technology rather than based on historical costs. A model was developed to determine the forward looking cost of providing service and support for large carriers. For smaller, independent carriers, the FCC maintained support based on a company's historical cost of service. The Commission followed suit. Support for AT&T and CenturyLink was modified based on a forward looking cost model. Support available to independent carriers is being determined through rate of return audits of each company. The Commission has completed audits for all but three of the independent carriers.

#### KUSF Supported Programs

As indicated above, the KUSF provides support for several uses all of which are intended to promote universal service. The largest portion of the support is provided to carriers who serve in high cost areas of the state. In Kansas, areas are usually viewed as high cost because of the low population density. In other states, geography can also contribute to the high cost nature of the service.

The fund also provides support for Lifeline, which is a program to provide discounted telephone service for low-income consumers. The KUSF currently provides a credit of \$7.77 per month for qualifying low-income consumers. The KUSF further supports Kansas Relay Services, Inc, which is a relay center for hearing-impaired customers, and the Telecommunications Access Program (TAP), which provides telecommunications equipment for disabled individuals.

#### KUSF Assessment

The Commission must set an assessment rate to be implemented March 1<sup>st</sup> of each year. The Commission gathers information regarding the anticipated expenditures from the fund and the estimated revenues of carriers contributing to the fund. The assessment is calculated by dividing the anticipated expenditures by the estimated revenues. Carriers are permitted, but not obligated, to pass the assessment to consumers on each bill. The incumbent local exchange carriers place an assessment on their bills that is calculated by dividing the projected assessment by the number of lines served by each carrier and is a fixed amount. All other carriers calculate an assessment rate based on the revenue generated by each customer. As an illustration of the calculation of the KUSF assessment, an exhibit from Staff's testimony filed in December 2009 supporting the new KUSF assessment is attached to this presentation as Attachment 1.



The history of the size of the KUSF is also provided as Attachment 2 to this presentation. The fund was established in 1997 with funding requirements of \$70,468,892. At its highest, the KUSF funding requirement was approximately \$100 million. The highest assessment rate was 9%. The lowest funding requirement was approximately \$60 million and the lowest assessment rate was 3.7%. On January 14, 2010, the Commission issued an order adopting an assessment rate for year fourteen of the fund which began March 1, 2010. The new funding requirement is approximately \$70 million and the new assessment rate is 6.06 %.

### Eligible Telecommunications Carriers

In fostering competition, the Federal Telecom Act and the Kansas Telecom Act permit competitive carriers to be designated as eligible telecommunications carriers (ETC) and receive universal service support if they meet certain requirements. The Commission has been responsible for determining whether carriers meet such requirements and for monitoring whether such carriers use the support they receive in an appropriate manner.

The Federal Telecom Act further required states to designate companies that were already receiving USF support (the incumbent local exchange carriers) as ETCs prior to December 31, 1997, to ensure continued receipt of those funds. In Kansas, the carriers were required to file an affidavit attesting that each carrier was able to provide the nine supported services and functionalities. All Kansas incumbent local exchange carriers were granted ETC designation by the Commission in an order dated December 5, 1997.

To be designated as a competitive ETC and receive universal service support, a carrier must, throughout the service area for which the designation is received,— (A) offer the services that are supported by Federal universal service support mechanisms under section 254(c) of the Federal Telecom Act<sup>2</sup>, either using its own facilities or a combination of its own facilities and resale of another carrier’s services (including the services offered by another eligible telecommunications carrier); and (B) advertise the availability of such service and the charges therefore using media of general distribution. Federal law, 47 U.S.C. § 214 (e)(2), states that “Upon request and consistent with the public interest, convenience, and necessity, the State commission may, in the case of an area served by a rural telephone company, and *shall*, in the case of all other areas, designate more than one common carrier as an eligible telecommunications carrier for a service area designated by the State commission.”

In its evaluation of whether granting a competitive ETC designation is in the public interest the Commission has adopted analysis used by the FCC. The Commission requires carriers to demonstrate the following:

- Benefits of Increased Competitive Choice
- Ability to Provide the Supported Services Throughout the Designated Service Area Within a Reasonable Time Frame

---

<sup>2</sup> 47 C.F.R. § 54.101(a) identifies the services or functionalities that shall be supported by federal universal service support mechanisms. The applicant must provide all of the following services that are designated for federal support: (1) voice-grade access to the public switched network; (2) local usage; (3) dual-tone multi-frequency (“DTMF”); (4) single-party service or its functional equivalent; (5) access to emergency services; (6) access to operator services; (7) access to interexchange services; (8) access to directory assistance; and (9) toll limitation for qualifying low-income consumers.

- Impact of Multiple Designations on the Universal Service Fund
- Unique Advantages and Disadvantages of the Competitor's Service Offering
- Commitments Made Regarding Quality of Telephone Service Provided By Competing Providers

The Commission also requires a competitive ETC applicant to demonstrate that it has sufficient back-up power to remain functional without external power in emergency situations, is able to reroute traffic around damaged facilities, and can manage emergency traffic spikes. Further, each applicant is required to file two-year service quality improvement plans demonstrating progress, including maps and if targets were not met an explanation of why on an annual basis.

To date, the Commission has found that eighteen carriers met requirements to be designated as competitive ETCs in order to receive USF support and nine of those eighteen carriers are eligible to receive KUSF support. Three of the eighteen competitive ETCs are eligible to receive only federal low-income (Lifeline) support.

In determining that an ETC has used support appropriately, the Commission requires ETCs to file data and narrative each year explaining how high cost support was used and indicating where support was spent. In addition, the Commission has determined that it should review how KUSF support is used as well. As a result of this review, the Commission has required an audit of one ETC to conduct a more in-depth review of whether support has been used appropriately. The company submitted its filing on February 15, 2010.

#### Relationship to USF

The USF also provides support for universal service in Kansas. Carriers receive support for serving in high cost areas and support for low-income consumers is also provided through the USF. By far, the most significant relationship between the KUSF and USF is in support for high cost service. For the incumbent carriers, the Commission takes into account the amount of USF a carrier receives in determining the amount of KUSF support necessary for the carrier. Thus, changes in USF support amounts have a direct effect on KUSF support.

As of 2008, Kansas ranks third in receipt of high cost support from the USF. Only Mississippi and Texas receive more high cost support. In 2009, carriers received approximately \$253 million in high cost support for Kansas service areas. From 1998 to 2008, carriers have received approximately \$1.4 billion in high cost support for Kansas service areas. The total benefit to Kansans would be reflected by subtracting out the contributions made by Kansas consumers. Once contributions are subtracted, Kansas is still a net receiver of support from the USF.

The majority of the high cost USF support for Kansas is paid to incumbent local exchange carriers. However, fifteen competitive carriers are eligible for high cost support from the USF. Competitive carriers were estimated to receive \$86 million. The majority of the competitive carriers are wireless carriers. Until recently, competitive carriers received the same amount of support per line as provided to the incumbent carrier. However, the FCC is considering whether this method of providing support is appropriate along with other considerations to reform the USF. The FCC has placed a cap on the amount of support available to competitive carriers until it makes a final determination on how to reform the USF.

# ATTACHMENT 1

Line	Description	Explanation	Year 14
<b><u>KUSF Obligations:</u></b>			
1	Rural LECs	Estimated KUSF support for rural LECs. Reflects KUSF support as of 12/1/09, revenue increases from rebalancing to target rates, and other known or estimated changes. (Attachment A)	\$ 25,630,287
2	SWBT	Estimated KUSF support for SWBT. Based on 9/30/2009 lines, the high-cost model adopted in Order Nos. 10 and 16, Docket No. 99-GIMT-326-GIT, and the remainder of LWC cost KUSF support for Nex-Tech and Sage. (confidential Attachment B)	7,021,093
3	United-Kansas d/b/a CenturyLink	Estimated KUSF support for the United Telephone of Kansas Companies d/b/a CenturyLink. [Dec. 30, 1999 Order, Docket No. 99-GIMT-326-GIT] and 9/30/2009 lines. (confidential Attachment C)	15,769,929
4	Nex-Tech, Inc.	Estimated KUSF support for Nex-Tech, Inc. under LWC. (confidential Attachment D)	44,304
5	Sage Telecom, Inc.	Estimated KUSF support for Sage under LWC. (confidential Attachment E).	70,980
6	H&B Cable	Estimated KUSF Support for H&B Cable. (confidential Attachment F)	32,856
7	Nex-Tech Wireless	Estimated KUSF Support for Nex-Tech Wireless. (confidential Attachment G)	4,299,228
8	Epic Touch Co.	Estimated KUSF Support for Epic Touch (confidential Attachment H)	76,486
9	United Wireless Communications	Estimated KUSF support for United Wireless Communications (confidential Attachment I)	776,964
10	Kansas Relay Service Inc. (KRSI)	KRSI budget as submitted by administrator to Staff. (Attachment J)	1,891,315
11	Telecommunications Access Program (TAP)	TAP budget as submitted by administrator to Staff (Attachment J). See also July 1998 Order, Docket No.96-GIMT-345-MIS.	827,123
12	Lifeline	Based on historical payments and 3% growth. (Attachment J)	2,745,255
13	Kan-Ed	Kan-Ed appropriations. (Attachment J)	10,000,000
14	Administration and Audits (GVNW, carrier audits, and third-party audits)	Based on KCC's contract with GVNW and estimated cost for GVNW's KUSF Carrier Revenue Audits (based on costs incurred July - November 2009) and WithumSmith + Brown Years 12 and 13 Financial Audits and Service Auditor's Reports, based on prior year's audit and report. (Attachment K)	552,424
15	<b>Gross KUSF Obligations</b>	The sum of lines 1 through 14.	\$ 69,738,244
16	<b>Less: Projected Year 13 Ending</b>	Estimated Reserve. (Attachment L)	(2,327,945)
17	<b>Adjusted KUSF Obligations</b>	KUSF to collect prior to Contingency Fund. Sum of Lines 15 and 16.	\$ 67,410,299
18	<b>Plus: Contingency Allowance</b>	Per Jan. 19, 2000 Year 4 Order, Docket 00-GIMT-236-GIT, the Contingency Allowance is 7.5% of Adjusted Funds	5,055,772
19	<b>Net KUSF To Collect</b>	Line 17 plus Line 18.	\$ 72,466,071

Line	Description	Explanation	Year 14
<b>RETAIL REVENUES:</b>			(3-1-2010)
1	Rural LECs	Provided by GVNW. Revenues reported by Rural LECs and projected .05% Revenue Growth. (Attachments A, M, & Q)	\$ 29,523,790
2	SWBT	Provided by GVNW. Based on revenues reported by SWBT and Staff projections. (confidential Attachment B, M, & Q)	** **
3	United Telephone Companies of Kansas d/b/a CenturyLink	Provided by GVNW. Based on revenues reported by CenturyLink and Staff growth projections. (confidential Attachments C, M, & Q)	** **
4	Wireless Providers	Provided by GVNW. Based on revenues reported by cellular/wireless carriers & Staff projections. (confidential Attachment N and Q)	726,554,059
5	IXCs/Others	Provided by GVNW. Based on revenues reported by all carriers other than LECs, VoIP, and Wireless/Paging providers and Staff projected reductions. (confidential Attachment O & Q)	197,609,949
6	VoIP	Provided by GVNW. Based on revenues reported by companies registered as VoIP and Staff projections. (Attachments P & Q)	8,857,387
7	<b>Total Assessable Revenue</b>	<b>Sum of Lines 1-6.</b>	<u>\$ 1,196,268,715</u>

<u>Line</u>	<u>Description</u>	<u>Explanation</u>	
1	NET KUSF REQUIREMENT	From page 1, line 19.	\$ 72,466,071
2	TOTAL PROJECTED RETAIL REVENUE	From page 2, line 7.	1,196,268,715
3	<b>Proposed KUSF Assessment Rate</b>	<b>Line 1 divided by Line 2.</b>	<u><u>6.06%</u></u>

# ATTACHMENT 2

**History of Kansas Universal Service Fund  
(KUSF)  
March 1997 - February 2004**

<b>Description</b>	<b>Year 1 3/1/1997</b>	<b>Year 2 Effective 6/1/1998</b>	<b>Year 3 3/1/1999</b>	<b>Year 4 3/1/2000</b>	<b>Year 5 3/1/2001</b>	<b>Year 6 3/1/2002</b>	<b>Year 7 3/1/2003</b>
Order Date	12/27/1997	4/29/1998	1/29/1999	1/19/2000	1/19/2001	1/22/2002	1/24/2003
Docket No.	94-GIMT-478-GIT	94-GIMT-478-GIT	94-GIMT-478-GIT	00-GIMT-236-GIT	01-GIMT-235-GIT	02-GIMT-161-GIT	03-GIMT-284-GIT
Size of Fund [1]	\$ 70,468,892	\$ 100,452,021	\$ 100,296,911	\$ 63,071,500	\$ 65,002,308	\$ 60,134,748	\$ 73,602,709
Amount toBe Collected [2]	77,788,220	68,756,420	85,824,741	60,270,500	58,760,820	49,073,331	65,739,179
Assessable Revenue [3]	\$ 864,361,690	\$ 1,006,520,487	\$ 1,125,051,194	\$ 1,225,326,005	\$ 1,270,067,963	\$ 1,326,562,228	\$ 1,316,330,994
<b><u>KUSF Rates:</u></b>							
Assessment	9.00%	6.83%	7.63%	4.92%	4.85%	3.70%	4.99%
Surcharge	9.89%	7.33%	8.26%	4.66%	4.38%	3.34%	Adopted one rate for all companies.
Wireless Assessment		6.49%	7.24%	Adopted one rate for wireline companies and a reduced rate for wireless companies.			
Wireless Surcharge		6.94%	7.81%				
<b><u>Wireless Reduction Factor [4]:</u></b> <i>(effective 10/98 through 2/03)</i>							
		5.03%	5.03%	5.03%	9.69%	9.69%	N/A
<b><u>Intrastate Safe Harbor</u></b>							
Wireless			85.00%	85.00%	85.00%	85.00%	71.50%
Paging			88.00%	88.00%	88.00%	88.00%	
Analog SMR			99.00%	99.00%	99.00%	99.00%	88.00%
							99.00%
<b><u>Per Line Amount [5]</u></b>							
SWBT	\$ 2.00	\$ 1.99 <sup>b</sup>	\$ 2.21 <sup>(c)</sup>	\$ 1.51	\$ 1.45	\$ 1.19	\$ 1.61
Sprint	1.35	1.37	1.55	0.97	1.15	0.98	1.43
Tri-County	1.07	0.87	0.96	0.33	0.54	0.42	0.70
Cass County	2.11	1.81	2.24	1.35	1.34	1.10	1.61
RLECs in Stipulation	1.43	1.41	1.50	0.79	0.63	0.49	0.77

**Notes:**

[1] The Size of the Fund reflects the sum of all monies needed to meet Fund obligations, plus monies for a contingency funding allowance.

[2] The Amount to Collect reflects the Size of the Fund, less any surplus reserve.

[3] The Assessable Revenue reflects the total intrastate retail revenue projected to be reported by carriers/companies to the KUSF during the Fiscal Year. The projections reflect intrastate access reductions, implemented consistent with KCC orders and state statute.

[4] Pursuant to K.S.A. 66-2008(b), the KCC reduced wireless providers' assessment by 5.03% effective 10/1/98. The Commission's July 9, 2002 Order, Docket 02-GIMT-161-GIT, adopted that all carriers will pay the same assessment rate,

[5] The Amount Per Line is the amount each Incumbent Local Exchange Carrier is authorized to collect from customers for Local Services.



**History of Kansas Universal Service Fund  
(KUSF)  
March 2004 - February 2010**

<b>Effective Date:</b>	<b>Year 8 3/1/2004</b>	<b>Year 9 3/1/2005</b>	<b>Year 9 10/1/2005</b>	<b>Year 10 3/1/2006</b>	<b>Year 11 3/1/2007</b>	<b>Year 12 3/1/2008</b>	<b>Year 13 3/1/2009</b>
Order Date	1/27/2004	1/27/2005	8/23/2005	1/23/2006	1/23/2007	1/22/2008	1/23/2009
Docket No.	04-GIMT-331-GIT	GIT	05-GIMT-260-GIT	06-GIMT-332-GIT	07-GIMT-276-GIT	08-GIMT-315-GIT	09-GIMT-272-GIT
Size of Fund [1]	\$ 66,781,685	\$ 61,517,756	\$ 68,797,737	\$ 73,159,583	\$ 62,381,108	\$ 65,162,614	\$ 66,044,114
Amount to Collect [2]	62,059,381	54,445,408	63,236,241	73,159,583	51,852,824	57,899,871	61,951,654
Assessable Revenue [3]	\$ 1,274,195,207	\$ 1,260,383,952	\$ 1,260,383,952	\$ 1,204,705,741	\$ 1,193,371,608	\$ 1,245,225,528	\$ 1,232,776,395
<b>KUSF Assessment Rate</b>	4.87%	4.32%	5.02%	6.07%	4.35%	4.65%	5.03%
<b>Intrastate Safe Harbor</b>							
Wireless/Cellular/PCS	71.50%	71.50%	71.50%	71.5%, Mar.-Sept.06 62.9%, Effective Oct. 06	62.90%	62.90%	62.90%
Paging	88.00%	88.00%	88.00%	88.00%	88.00%	88.00%	88.00%
Analog SMR	99.00%	99.00%	99.00%	99.00%	99.00%	99.00%	99.00%
Interconnected VoIP [4]	N/A	N/A	N/A	N/A	N/A	35.10%	35.10%
<b>Per Line Amount [5]:</b>							
SWBT f/k/a AT&T, SBC) \$	1.50	\$ 1.31	\$ 1.52	\$ 1.78	\$ 1.30	\$ 1.37	\$ 1.52
Embarq (f/k/a Sprint)	1.54	1.36	1.58	1.82	1.21	1.36	1.49
RLECs in Stipulation [6]	0.87	0.79	0.92	1.14	0.88	1.01	1.15
Tri-County	0.76	0.96	1.11	1.25	0.88	N/A	N/A
Cass County	1.66	1.48	1.72	1.98	0.88	N/A	N/A

**Notes:**

- [1] The Size of the Fund, or Gross KUSF Requirement, recognizes the total monies needed to meet Fund obligations. The KUSF reserve and contingency funding are excluded.
- [2] The Amount to Collect, or Net Adjusted KUSF Requirement, reflects the total monies to collect from carriers. It includes all identified KUSF payments, the reserve, and contingency funding. In Year 10, the Size of the Fund and the Amount to Collect were the same, due to a minimal surplus balance and recognition of a liability resulting from Bluestem et. al. vs. KCC
- [3] The Assessable Revenue reflects the total intrastate retail revenue projected to be reported by carriers/companies to the KUSF during the Fiscal Year. The projections reflect intrastate access reductions, implemented consistent with KCC orders and state statute.
- [4] The September 2008 Order, Docket No. 07-GIMT-432-GIT, implemented the requirement for Interconnected VoIP providers to report to the KUSF, effective January 2009. Interconnected VoIP providers are allowed to apply the inverse of the FCC's Safe Harbor, or 35.10% to determine Kansas revenue for KUSF purposes
- [5] The Amount Per Line is the amount each Incumbent Local Exchange Carrier is authorized to collect from customers for Local Service.
- [6] See Commission's December 4, 2006 Order Granting Tri-County's and FairPoint Missouri's Motion to participate in RLEC Stipulation, approved Dec. 27, 1996 in Docket No. 94-GIMT-478-GIT. Effective March 1, 2007, the Per Line Assessment is the same for all Rural LECs.

# ATTACHMENT 3

Kansas Universal Service Fund (KUSF) Support  
Paid to Carriers  
(3/1/1997 to 2/2/002)

Carrier	Year 1 (3/97-2/98)	Year 2 (3/98-2/99)	Year 3 (3/99-2/00)	Year 4 (3/00-2/01)	Year 5 (3/01-2/02)	Total (3/97-2/02)
Bluestem	\$ 169,316	\$ 169,317	\$ 169,685	\$ 259,455	\$ 235,750	\$ 1,003,523
Blue Valley	475,153	468,889	467,017	979,180	1,098,319	3,488,558
Cass County	31,172	31,960	33,850	58,081	57,576	212,639
Columbus	97,111	67,999	41,409	167,398	149,070	522,987
Council Grove	17,773	-	-	86,993	75,616	180,382
CrawKan	295,743	295,743	295,743	2,123,826	1,830,363	4,841,418
Cunningham	533,448	533,448	533,448	651,858	709,793	2,961,995
Elkhart	-	-	-	312,432	365,950	678,382
Golden Belt	883,514	883,514	883,514	1,230,320	1,246,952	5,127,814
Gorham	36,702	36,610	36,567	55,972	57,656	223,507
Haviland	464,305	373,765	357,275	614,830	593,323	2,403,498
H & B	544,720	522,616	518,031	572,322	577,968	2,735,657
Home	529,392	515,264	526,675	689,102	689,475	2,949,908
JBN	509,790	509,790	522,661	833,711	828,153	3,204,105
KanOkla	642,033	643,230	644,595	767,240	769,137	3,466,235
LaHarpe	33,740	31,184	31,184	69,366	74,128	239,602
Madison	269,088	269,088	269,310	356,767	346,070	1,510,323
MoKan Dial	24,984	-	-	453,667	906,758	1,385,409
Moundridge	422,819	422,819	431,891	776,796	778,901	2,833,226
Mutual	23,692	24,984	24,984	80,125	81,154	234,939
Peoples	123,890	122,157	125,402	262,387	281,361	915,197
Pioneer	878,953	581,177	513,194	2,079,796	1,810,975	5,864,095
Rainbow	135,563	135,562	145,335	247,133	256,326	919,919
Rural	3,476,180	3,661,706	3,661,706	4,624,650	4,613,181	20,037,423
S & A	551,184	549,700	549,433	619,889	625,196	2,895,402
S & T	1,044,350	1,403,205	1,403,205	1,677,901	1,678,931	7,207,592
South Central	534,381	514,742	514,742	530,641	533,030	2,627,536
Southern KS	41,372	-	-	3,699,981	3,903,478	7,644,831
Southwestern Bell a/k/a AT&T	40,025,600	65,042,907	65,042,907	17,521,452	13,024,477	200,657,343
Sprint/United of KS	7,790,640	14,349,993	14,349,993	11,072,784	11,402,510	58,965,920
Sunflower	1,319,910	1,257,238	1,267,970	1,483,997	1,343,593	6,672,708
Totah	273,766	273,067	274,727	347,578	353,041	1,522,179
Tri-County	232,502	234,027	235,244	418,309	428,022	1,548,104
Twin Valley	693,262	701,928	705,395	893,489	920,038	3,914,112
United Telephone Assn	316,056	201,435	182,462	617,429	761,197	2,078,579
Wamego	-	-	-	218,254	308,190	526,444
Wheat State	667,876	671,600	671,600	911,281	935,539	3,857,896
Wilson	833,350	835,895	835,895	1,170,703	1,011,399	4,687,242
Zenda	81,924	81,923	82,145	98,119	104,897	449,008
Western Wireless [b]	N/A	N/A	N/A	30,031	31,135	61,166
<b>Total</b>	<b>\$ 65,025,254</b>	<b>\$ 96,418,482</b>	<b>\$ 96,349,194</b>	<b>\$ 59,665,245</b>	<b>\$ 55,798,628</b>	<b>\$ 373,256,803</b>

Notes:

- [a] Year 1 KUSF Support amounts are prior to any offset for rebalancing rates to the statewide average.  
[b] Reflects actual KUSF support paid to Western Wireless.

Kansas Universal Service Fund (KUSF) Support  
Paid to Carriers  
(3/2002 to 2/2007)

Carrier	Year 6 (3/02-2/03)	Year 7 (3/03-2/04)	Year 8 (3/04-2/05)	Year 9 (3/05-2/06)	Year 10 (3/06 - 2/07)	Total (3/02-2/07)
Bluestem	\$ 50,478	\$ 139,350	\$ -	\$ 15,038	\$ 15,038	\$ 219,904
Blue Valley	909,228	684,835	612,211	788,998	795,824	3,791,096
Cass County [a]	58,019	66,248	57,704	56,908	-	238,879
Columbus [b]	50,704	-	-	-	-	50,704
Council Grove	74,289	103,550	711,715	1,177,670	1,177,670	3,244,894
CrawKan	1,459,344	2,194,637	1,855,253	2,013,935	2,013,935	9,537,104
Cunningham	708,202	770,021	736,248	628,476	587,495	3,430,442
Elkhart	350,868	468,078	468,078	495,326	206,334	1,988,684
FairPoint Missouri [c]	-	-	-	-	-	-
Golden Belt [d]	1,245,661	1,739,144	540,416	-	-	3,525,221
Gorham	57,217	85,483	77,515	78,352	144,343	442,910
Haviland	585,618	869,262	1,006,772	1,178,004	1,178,004	4,817,660
H & B	571,520	635,224	616,159	620,200	682,936	3,126,039
Home	646,200	820,852	806,494	841,912	841,912	3,957,370
JBN	711,788	321,347	321,347	383,489	383,489	2,121,460
KanOkla	767,665	938,894	892,252	942,699	941,891	4,483,401
LaHarpe	73,325	209,389	199,633	249,527	249,527	981,401
Madison	346,515	377,970	373,888	374,845	374,845	1,848,063
MoKan Dial [e]	909,633	1,189,640	-	22,384	22,384	2,144,041
Moundridge [f]	779,830	469,635	-	-	-	1,249,465
Mutual	80,677	112,288	112,288	119,826	119,826	544,905
Peoples	283,429	360,109	358,500	367,052	367,052	1,736,142
Pioneer	2,878,119	3,401,527	3,032,983	3,068,660	3,068,660	15,449,949
Rainbow	252,460	385,588	344,398	367,989	367,989	1,718,424
Rural	4,039,753	4,252,626	4,068,765	4,267,840	4,347,471	20,976,455
S & A	623,319	498,970	444,855	451,257	451,257	2,469,658
S & T	1,405,968	1,015,774	986,605	1,052,515	1,052,515	5,513,377
South Central	541,608	637,931	612,755	880,421	426,166	3,098,881
Southern KS	974,650	1,487,371	1,363,147	1,387,409	1,387,409	6,599,986
Southwestern Bell a/k/a A'	10,500,596	9,397,260	8,913,467	8,451,477	8,286,106	45,548,906
Sunflower [g]	7,057	43,233	-	-	-	50,290
Totah	352,609	522,967	489,127	460,182	342,946	2,167,831
Tri-County	427,764	606,215	528,531	1,356,399	1,868,783	4,787,692
Twin Valley [h]	920,040	1,051,368	1,401,878	1,441,078	3,035,316	7,849,680
United Telephone Assn	760,680	1,153,348	829,107	308,588	308,588	3,360,311
United of KS d/b/a Embarq	11,436,996	11,660,366	10,717,734	11,149,865	9,523,877	54,488,838
Wamego	290,051	498,973	385,493	494,482	519,484	2,188,483
Wheat State	928,574	1,027,316	897,767	935,551	935,551	4,724,759
Wilson	929,030	1,002,941	951,359	967,216	967,216	4,817,762
Zenda	104,830	123,771	120,487	128,970	128,970	607,028
H&B Cable	N/A	N/A	31	11,528	11,617	23,176
Nex-Tech, Inc.	N/A	2,978	15,957	14,404	34,409	67,748
Nex-Tech Wireless	N/A	N/A	N/A	N/A	193,562	193,562
Sage Telecom	N/A	N/A	N/A	N/A	43,906	43,906
Western Wireless [i]	76,796	285,934	269,816	423,280	-	1,055,826
<b>Total</b>	<b>\$ 48,171,110</b>	<b>\$ 51,612,413</b>	<b>\$ 46,120,735</b>	<b>\$ 47,973,752</b>		<b>\$ 241,282,313</b>

Notes:

- [a] Effective 3/1/2006, Cass County no longer received KUSF support, pursuant to Docket No. 05-GIMT-094-GIT.
- [b] Effective 3/1/2003, Columbus no longer received KUSF support, pursuant to Docket No. 03-CBST-778-TAR.
- [c] FairPoint Missouri purchased Cass County and does not receive KUSF support, pursuant to Docket No. 05-GIMT-094-GIT.
- [d] Effective 7/1/2004, Golden Belt no longer received KUSF support, pursuant to Docket No. 04-GNBT-130-AUD.
- [e] Effective 3/1/2004, MoKan did not receive KUSF support, per Docket No. 04-MRNT-364-AUD and then received support due to intrastate access rate adjustments.
- [f] Effective 8/1/2003, Moundridge no longer received KUSF support, pursuant to Docket No. 04-MRGT-1117-AUD.
- [g] Effective 6/1/2003, Sunflower no longer received KUSF support, pursuant to Docket No. 01-SFLT-879-AUD.
- [h] Effective 3/1/2006, Twin Valley's KUSF support includes support for the exchanges purchased from Embarq, per Docket No. 09-TWVT-069-KSF.
- [i] Reflects actual KUSF support paid to Western Wireless, see Docket No. 08-GIMT-315-GIT. Effective 1/1/2006, KUSF support was no longer paid for the property since it was purchased by U.S. Cellular.

**Kansas Universal Service Fund (KUSF) Support  
Paid to Carriers  
(3/2007 to 2/2010)**

Carrier	Year 11 (3/07-2/08)	Year 12 (3/08-2/09)	Year 13 [Est.] (3/09-2/10)	Total (3/07-2/10)
Bluestem	\$ -	\$ -	\$ -	\$ -
Blue Valley	723,134	694,068	545,631	1,962,833
Columbus [a]	-	68,750	40,884	109,634
Council Grove	1,143,609	1,121,445	1,049,078	3,314,132
CrawKan	1,592,271	1,447,143	1,206,949	4,246,363
Cunningham	544,621	530,043	474,334	1,548,998
Elkhart	95,570	94,130	65,153	254,853
FairPoint Missouri	-	-	-	-
Golden Belt	-	-	-	-
Gorham	233,857	220,305	199,411	653,573
Haviland	1,144,711	1,103,203	1,038,595	3,286,509
H & B	789,509	779,873	742,998	2,312,380
Home	797,648	775,196	687,724	2,260,568
JBN	299,745	275,577	217,027	792,349
KanOkla	897,028	873,736	788,417	2,559,181
LaHarpe	242,820	238,164	195,524	676,508
Madison	306,220	270,348	249,060	825,628
MoKan Dial	-	-	-	-
Moundridge [b]	50,000	600,000	411,038	1,061,038
Mutual [c]	109,126	115,821	253,217	478,164
Peoples	303,766	252,126	214,920	770,812
Pioneer	2,739,308	2,573,744	2,173,177	7,486,229
Rainbow	353,456	333,799	248,322	935,577
Rural	4,246,848	4,134,153	3,770,795	12,151,796
S & A	436,826	426,602	400,660	1,264,088
S & T	1,000,349	973,445	881,266	2,855,060
South Central	392,404	375,220	321,782	1,089,406
Southern KS	1,439,576	1,380,260	1,324,601	4,144,437
Southwestern Bell d/b/a AT&T [d]	7,946,568	7,733,329	7,751,513	23,431,410
Sunflower	-	-	-	-
Totah	314,129	299,657	179,056	792,842
Tri-County	1,771,175	1,733,327	1,607,197	5,111,699
Twin Valley [e]	2,993,551	3,069,491	3,935,069	9,998,111
United Telephone Assn	182,774	120,218	72,009	375,001
United of KS d/b/a Embarq	9,811,242	12,391,763	14,257,689	36,460,694
Wamego	433,721	367,061	152,432	953,214
Wheat State	873,853	844,969	756,961	2,475,783
Wilson	918,092	893,156	843,679	2,654,927
Zenda	121,411	119,143	100,130	340,684
Epic Touch	84,779	92,444	82,307	259,530
H&B Cable [f]	17,069	23,298	25,393	65,760
Nex-Tech, Inc.	49,060	40,948	42,090	132,098
Nex-Tech Wireless [g]	1,758,253	2,828,473	3,077,837	7,664,563
Sage Telecom [h]	58,849	55,287	66,550	180,686
United Wireless Communications [i]	-	-	-	-
<b>Total</b>	<b>\$ 47,216,928</b>	<b>\$ 50,269,715</b>	<b>\$ 50,450,475</b>	<b>\$ 147,937,118</b>

**Notes:**

[a] Columbus began receiving KUSF support, effective 4/1/2008. (3/27/2008 Order, Docket No. 08-CBST-400-KSF).

[b] Effective 2/1/2008, Moundridge receives \$600,000 of annual KUSF support, determined in Docket No. 08-MRGT-221-KSF.

[c] Effective 1/1/2009, Mutual's annual KUSF support was increased \$14,417 a month, for January and February 2008 data months, as determined in

[d] Includes KUSF support associated with Nex-Tech, Inc. and Sage Telecom provisioning service via LWC.

[e] Effective 2/1/2009, Twin Valley's KUSF support determined in Docket No. 08TWT-069-KSF includes KUSF support for the exchanges purchased

[f] H&B Cable received KUSF support for the period March 2007 - February 2009 in Docket No. 09-GJMT-272-GIT.

[g] Includes supplemental KUSF support approved in Docket Nos. 08-NTWZ-1084-KSF, 09-NTWZ-176-KSF, and 09-NTWZ-418-KSF. Total subject to change based on company's request for supplemental KUSF, effective 1/2009, in Docket No. 09-NTWZ-665-KSF

[h] Sage received KUSF support, retroactive to July 2006, in Docket No. 08-SAGT-617-KSF.

[i] United Wireless Communications filed a request for KUSF support, retroactive to August 2007, in Docket No. 08-UWCC-1101-KSF.

# ATTACHMENT 4

Federal USF Support Received by Carriers in Kansas

Company	High Cost FUSF Support
EMBARQ	\$15,636,255
BLUE VALLEY TELEPHONE COMPANY	\$4,870,464
COLUMBUS TELEPHONE COMPANY	\$195,726
COUNCIL GROVE TEL. CO.	\$2,081,901
CUNNINGHAM TELEPHONE CO. INC.	\$1,151,133
ELKHART TELEPHONE COMPANY INC.	\$1,328,190
GOLDEN BELT TELEPHONE ASSN. INC.	\$6,151,368
GORHAM TELEPHONE COMPANY INC.	\$394,167
HAVILAND TELEPHONE COMPANY INC.	\$5,337,594
H & B COMMUNICATIONS INC.	\$911,040
HOME TELEPHONE COMPANY INC.	\$1,960,062
J. B. N. TELEPHONE COMPANY INC.	\$1,947,084
KANOKLA TEL. ASSOC. INC.- KS	\$4,275,984
LA HARPE TELEPHONE COMPANY INC.	\$335,316
MADISON TELEPHONE, LLC	\$998,562
MOKAN DIAL, INC.- KS	\$1,648,218
MOUNDRIDGE TEL. CO.	\$2,579,934
MUTUAL TELEPHONE COMPANY	\$593,202
PEOPLES TELECOMMUNICATIONS, LLC	\$2,250,333
PIONEER TELEPHONE ASSOCIATION INC.	\$9,114,603
CRAW-KAN TELEPHONE COOP INC- KS	\$4,554,351
RAINBOW TEL COOPERATIVE ASSN INC.	\$2,751,108
RURAL TEL. SERVICE CO.,INC.	\$18,618,399
S & T TEL. COOP. ASSN.	\$7,077,465
S & A TEL. CO.,INC.	\$1,220,511
SOUTH CENTRAL TEL. ASSN. INC.-KS	\$4,162,773
SOUTHERN KANSAS TEL. CO.,INC.	\$6,141,336
SUNFLOWER TEL. CO.,INC.	\$1,955,316
TRI-COUNTY TEL. ASSN. INC.-KS	\$4,650,108
TWIN VALLEY TEL. INC.-KS	\$2,861,643
UNITED TELEPHONE ASSN. INC.	\$5,382,960
WAMEGO TELEPHONE COMPANY INC.	\$2,475,021
WHEAT STATE TELEPHONE, INC.	\$2,144,103
WILSON TELEPHONE COMPANY INC.	\$2,074,611
ZENDA TELEPHONE COMPANY INC.	\$283,611
TOTAH TELEPHONE CO. INC.	\$1,228,005
SOUTHWESTERN BELL-KANSAS	\$504,270

Company	High Cost FUSF Support
WESTERN WIRELESS	\$3,669,513
SPRINT SPECTRUM LP / PHILLIECO LP (DBA SPRINT PCS)	\$2,229,402
RCC MINNESOTA, INC.	\$4,112,703
NEX-TECH, INC.	\$195,042
H&B CABLE SERVICE, INC.	\$1,788
ALLTEL COMMUNICATIONS (WIRELESS KS)	\$45,105,540
USCOC OF NEBRASKA/KANSAS LLC	\$56,613
NEX-TECH WIRELESS, LLC	\$5,901
UNITED WIRELESS COMMUNICATION INC.	\$522
EPIC TOUCH COMPANY	\$0

Total FUSF Support to Carriers in Kansas	\$187,223,751
Commission Must Certify Use	\$184,808,079
Carriers Certify Directly to FCC	\$2,415,672